

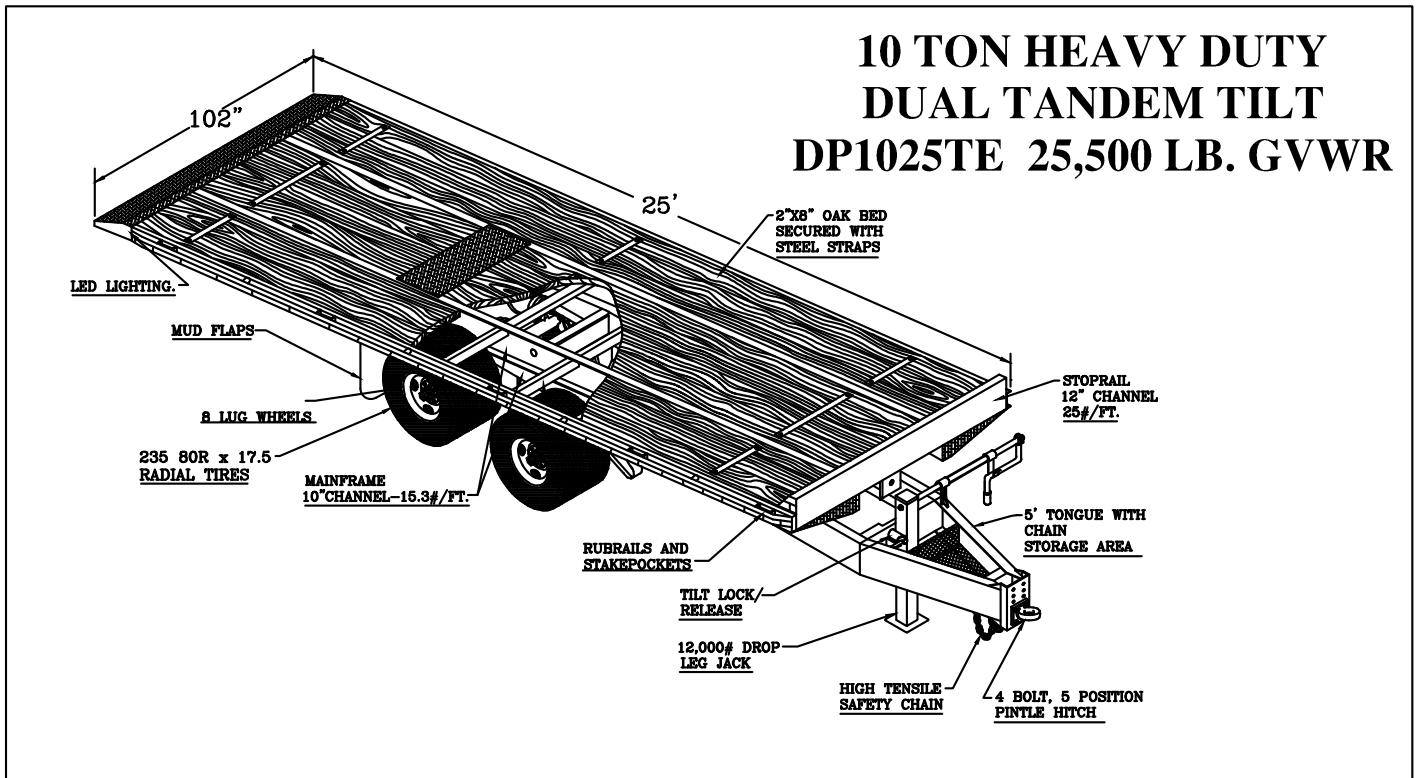

WORKING TRAILERS
FOR A WORKING WORLD



AVAILABLE OPTIONS:

WINCH PLATE
CHAIN STORAGE WITH LOCKING LID
POWER TILT
DUAL OR TWO SPEED JACKS
STEEL TREAD PLATE DECKING
FORK TUBES
CUSTOM COLOR CHOICE
ADDITIONAL TONGUE LENGTH
ALL REQUESTS CONSIDERED

MISCELLANEOUS SPECS:

ELECTRIC BRAKES
(2) COMMERCIAL GRADE, 10,000 LB. CAPACITY AXLES
HIGH VISIBILITY ECONOLINE YELLOW ACRYLIC PAINT
FRACTURE RESISTANT MIG WELDING
SEALED WIRING HARNESS
DOT REQUIRED SAFETY DECALS, LIGHTING, AND CONSPICUITY MARKINGS INCLUDING TAG LIGHT AND HOLDER
36 IN. BED HEIGHT FROM GROUND (APPROX.)
LED LIGHTS



Double Springs, Alabama
1-800-624-1866

www.econolinetrailers.com

MODEL:	DP1025TE	LAST REVISED:	03/03/15
--------	----------	---------------	----------